

DC-DC converter from 5 V to 12 V, 0.03 A for Flash memory programming supply

Features

- Output voltage: 12 V \pm 5 %
- Supply voltage range: 4.5 V to 5.5 V
- Guaranteed output current up to 30 mA
- Very low quiescent current: 100 μ A
- Logic controlled electronic shutdown: 1 μ A
- Just capacitors needed (no inductor)

Description

The ST662A is a regulated charge pump DC-DC converter. It provides 12 V \pm 5 % output voltage to program byte-wide Flash memory, and can supply 30 mA output current from input as low as 4.75 V. A logic controlled shut down pin that interfaces directly with microprocessor reduces the supply current to only 1 μ A. The ST662AB is available as Automotive Grade in SO-8 package. This device is qualified according to the specification AEC-Q100 of the Automotive market, in the temperature range - 40 °C to 125 °C, and the statistical tests PAT, SYL, SBL are performed.

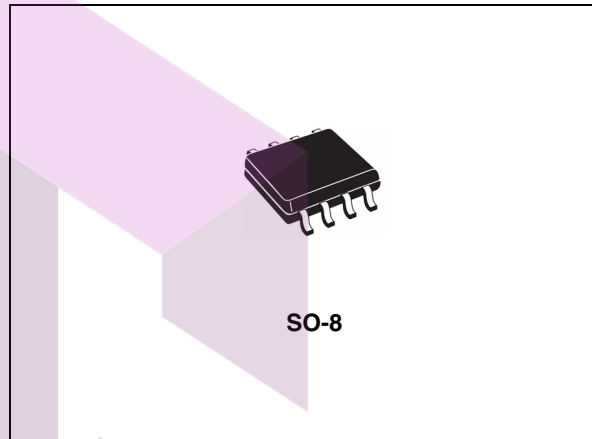

Table 1. Device summary

Order codes	Package
ST662ABD-TR	SO-8 (tape and reel)
ST662ABD-TRY ⁽¹⁾	SO-8 (tape and reel)
ST662ACD-TR	SO-8 (tape and reel)

1. Automotive Grade products.

Contents

1	Application circuit	3
2	Pin configuration	4
3	Maximum ratings	5
4	Electrical characteristics	6
5	Typical performance characteristics	7
6	Description	9
7	Application circuit	11
	7.1 ST662A output performance	12
8	How to increase output current or output voltage capability	14
9	Package mechanical data	16
10	Revision history	19

SKYTECH

تهیه و توزیع قطعات الکترونیک

1 Application circuit

Figure 1. Typical application circuit

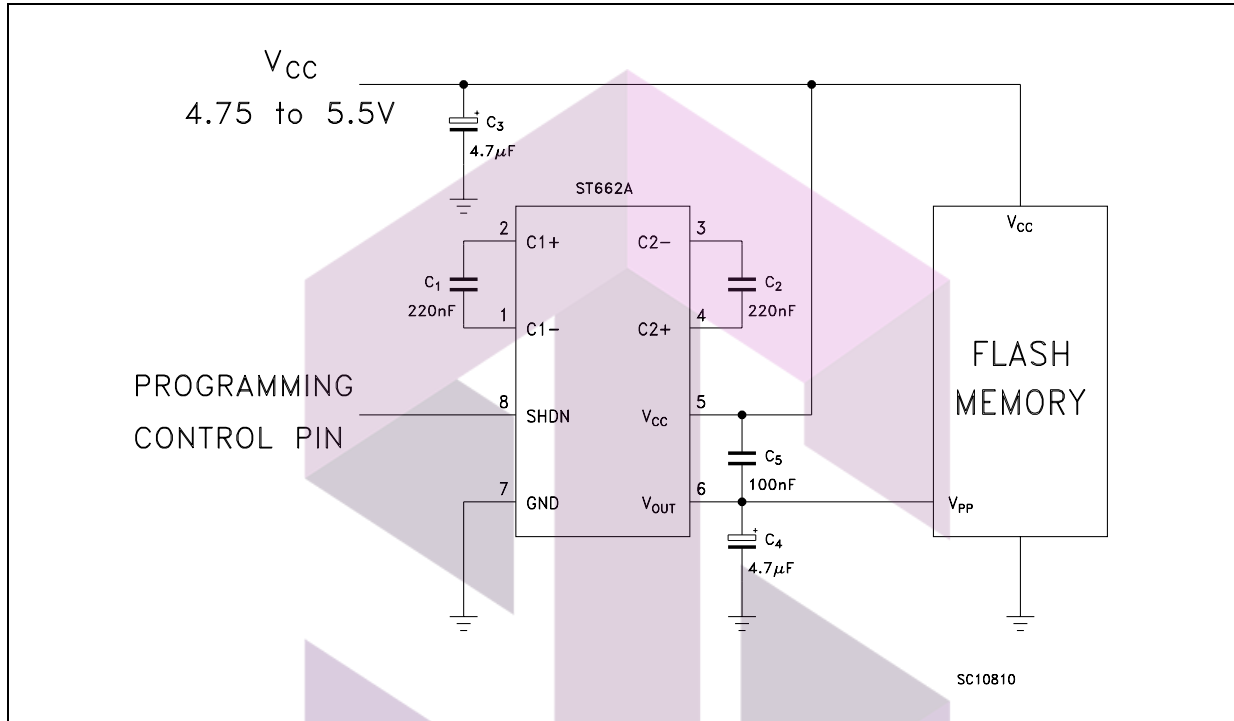

SKYTECH

تهیه و توزیع قطعات الکترونیک

2 Pin configuration

Figure 2. Pin connections (top view)

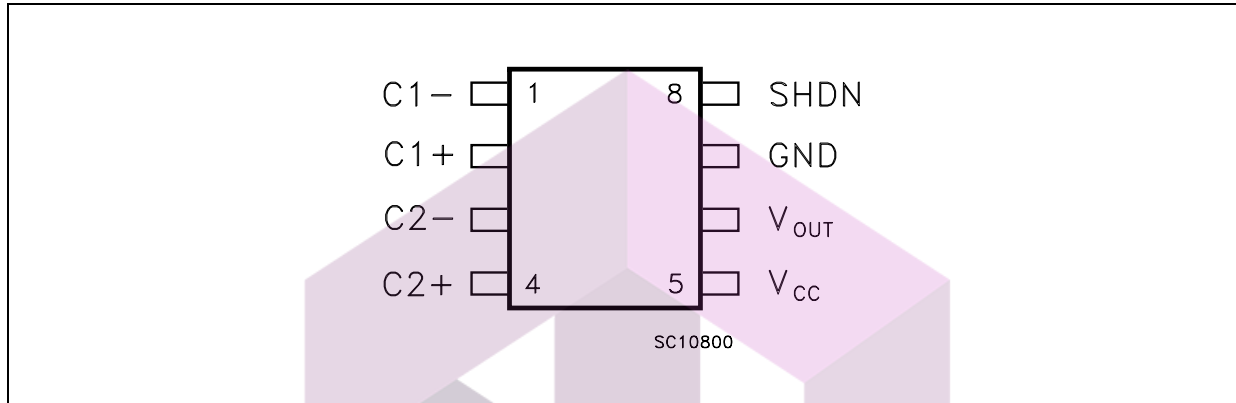

Table 2. Pin description

Pin n°	Symbol	Name and function
1	C1-	Negative terminal for the first charge pump capacitor
2	C1+	Positive terminal for the first charge pump capacitor
3	C2-	Negative terminal for the second charge pump capacitor
4	C2+	Positive terminal for the second charge pump capacitor
5	V _{CC}	Supply voltage
6	V _{OUT}	12 V output voltage V _{OUT} = V _{CC} when in shutdown mode
7	GND	Ground
8	SHDN	Active high C-MOS logic level shutdown input. SHDN is internally pulled up to V _{CC} . Connect to GND for normal operation. In Shutdown mode the charge pumps are turned off and V _{OUT} = V _{CC}

SKYTECH

تهیه و توزیع قطعات الکترونیک

3 Maximum ratings

Table 3. Absolute maximum ratings

Symbol	Parameter	Value	Unit
V_{CC}	DC input voltage to GND	-0.3 to 6	V
SHDN	Shutdown voltage	-0.3 to ($V_{CC} + 0.3$)	V
I_O	Output current continuous	50	A
P_D	Power dissipation	500	mW
T_{OP}	Operating ambient temperature range	AC series	0 to 70
		AB series	-40 to 85
T_{STG}	Storage temperature range	-40 to 150	°C

Note: Absolute maximum ratings are those values beyond which damage to the device may occur. Functional operation under these condition is not implied.

Table 4. Thermal data

Symbol	Parameter	SO-8	Unit
R_{thJC}	Thermal resistance junction-case	20	°C/W

SKYTECH

تهیه و توزیع قطعات الکترونیک

4 Electrical characteristics

Refer to the test circuits, $V_{CC} = 4.5\text{ V to }5.5\text{ V}$, $T_A = T_{MIN}$ to T_{MAX} , unless otherwise specified. Typical value are referred at $T_A = 25\text{ }^\circ\text{C}$.

Table 5. Electrical characteristics

Symbol	Parameter	Test conditions	Min.	Typ.	Max.	Unit
V_O	Output voltage	$I_O = 0\text{ to }20\text{ mA}$	11.4	12	12.6	V
		$I_O = 0\text{ to }30\text{ mA}$, $V_{CC} = 4.75\text{ to }5.5\text{ V}$	11.4	12	12.6	
I_{Q1}	Quiescent current	NO LOAD, $V_{SHDN} = 0$		100	500	μA
I_{Q2}	Shutdown current	NO LOAD, $V_{SHDN} = V_{CC}$		1	10	μA
I_{SH}	Shutdown pin current	$V_{SHDN} = 0$, $V_{CC} = 5\text{ V}$	-50	-12	-5	μA
		$V_{SHDN} = V_{CC} = 5\text{ V}$		0		μA
V_{IL}	Shutdown input low threshold				0.4	V
V_{IH}	Shutdown input high threshold		2.4			V
f_O	Oscillator frequency	$V_{CC} = 5\text{ V}$, $I_O = 30\text{ mA}$		400		kHz
n	Power efficiency	$V_{CC} = 5\text{ V}$, $I_O = 30\text{ mA}$		72		%
R_{SW}	$V_{CC} - V_{OUT}$ switch impedance	$V_{SHDN} = V_{CC} = 5\text{ V}$, $I_O = 100\text{ }\mu\text{A}$		1	2	$\text{k}\Omega$

Refer to the test circuits, $V_{CC} = 4.5\text{ V to }5.5\text{ V}$, $T_A = -40\text{ to }125\text{ }^\circ\text{C}$, unless otherwise specified. Typical value are referred at $T_A = 25\text{ }^\circ\text{C}$.

Table 6. Electrical characteristics for ST662AB-TRY (Automotive Grade)

Symbol	Parameter	Test conditions	Min.	Typ.	Max.	Unit
V_O	Output voltage	$I_O = 0\text{ to }20\text{ mA}$	11.2	12	12.8	V
		$I_O = 0\text{ to }30\text{ mA}$, $V_{CC} = 4.75\text{ to }5.5\text{ V}$	11.2	12	12.8	
I_{Q1}	Quiescent current	NO LOAD, $V_{SHDN} = 0$		100	500	μA
I_{Q2}	Shutdown current	NO LOAD, $V_{SHDN} = V_{CC}$		1	15	μA
I_{SH}	Shutdown pin current	$V_{SHDN} = 0$, $V_{CC} = 5\text{ V}$	-50	-12	-5	μA
		$V_{SHDN} = V_{CC} = 5\text{ V}$, $T_A = 25\text{ }^\circ\text{C}$		0		μA
V_{IL}	Shutdown input low threshold				0.4	V
V_{IH}	Shutdown input high threshold		2.4			V
f_O	Oscillator frequency	$V_{CC} = 5\text{ V}$, $I_O = 30\text{ mA}$, $T_A = 25\text{ }^\circ\text{C}$		400		kHz
n	Power efficiency	$V_{CC} = 5\text{ V}$, $I_O = 30\text{ mA}$, $T_A = 25\text{ }^\circ\text{C}$		72		%
R_{SW}	$V_{CC} - V_{OUT}$ switch impedance	$V_{SHDN} = V_{CC} = 5\text{ V}$, $I_O = 100\text{ }\mu\text{A}$		1	2	$\text{k}\Omega$

تهیه و توزیع قطعات الکترونیک

5 Typical performance characteristics

Figure 3. Output voltage vs. temperature
($I_{OUT} = 50\text{ mA}$)

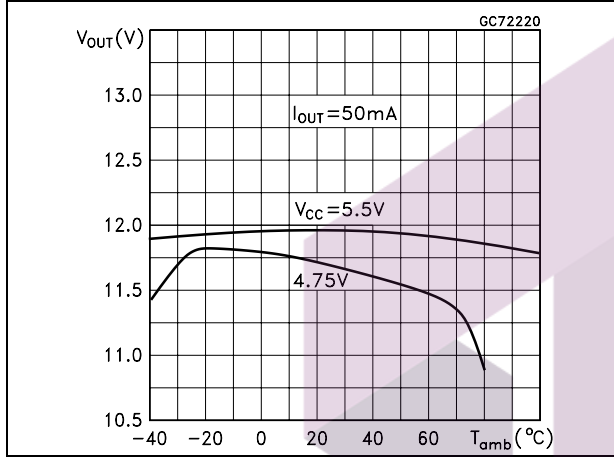

Figure 4. Output voltage vs. temperature
($I_{OUT} = 30\text{ mA}$)

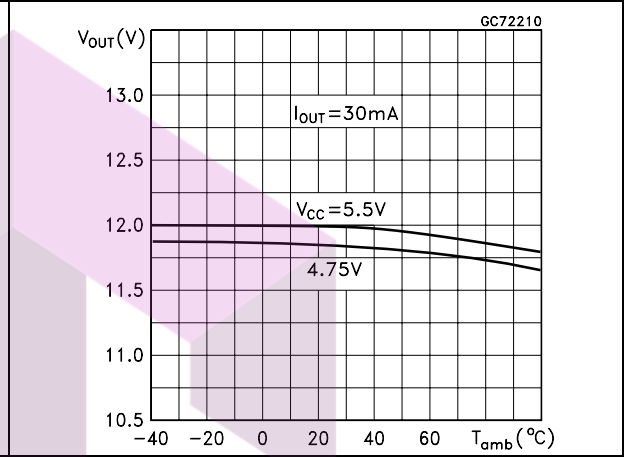

Figure 5. Supply current vs. temperature

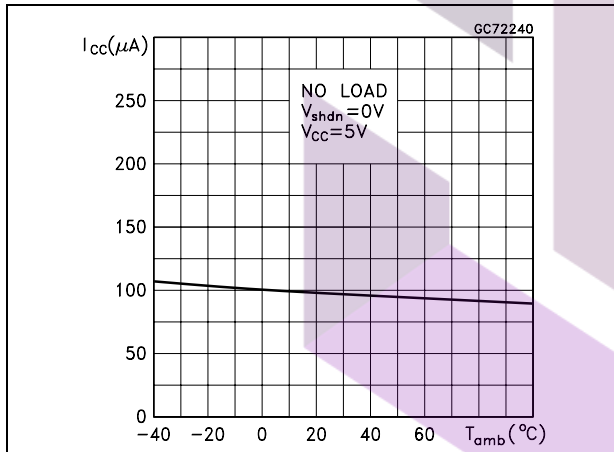

Figure 6. Supply current vs. supply voltage

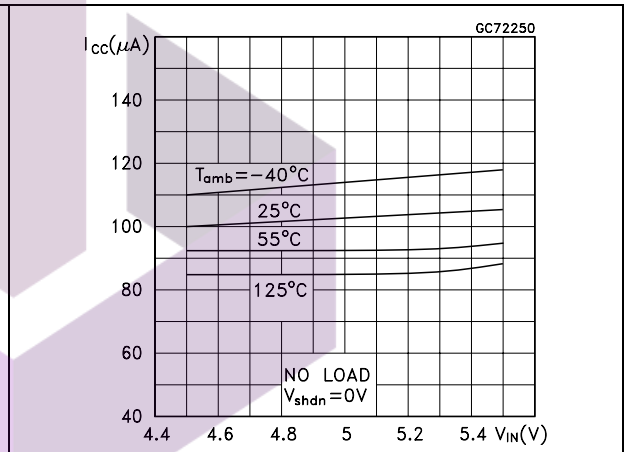

Figure 7. SHDN pin current vs. temperature

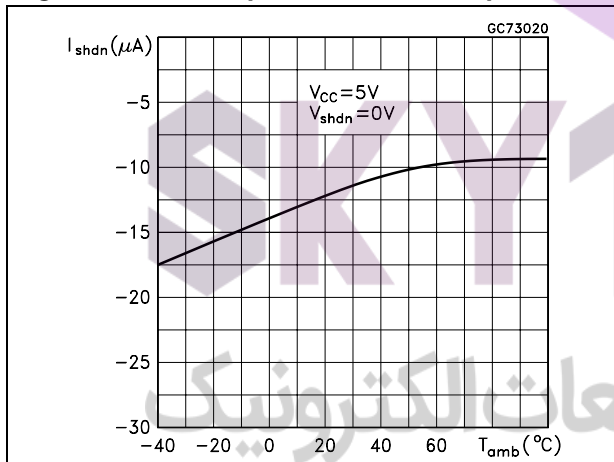

Figure 8. Output voltage vs. shutdown input

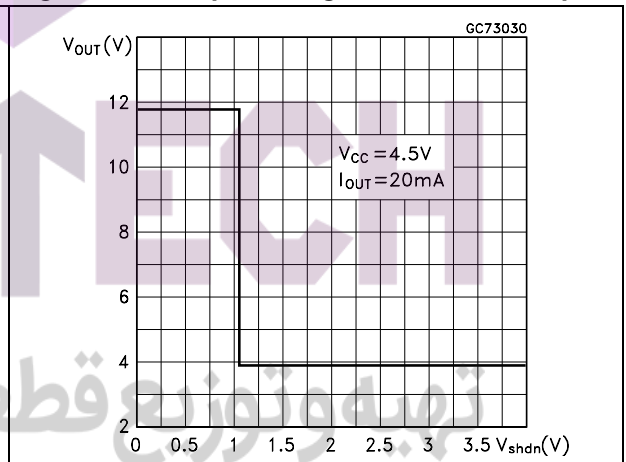

Figure 9. Output voltage vs. shutdown input voltage (No load)

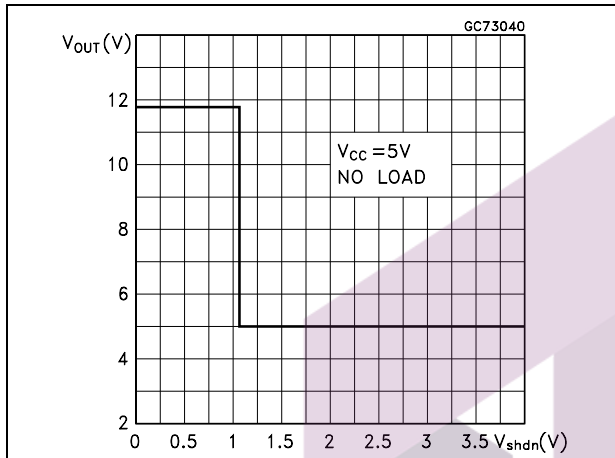

Figure 10. Output voltage vs. shutdown input voltage ($I_{OUT} = 30\text{ mA}$)

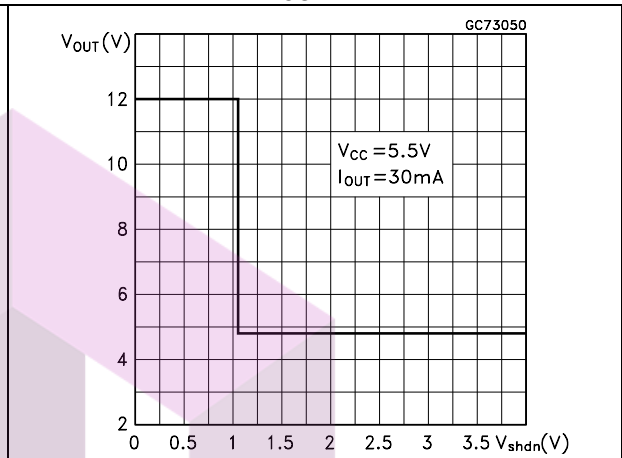
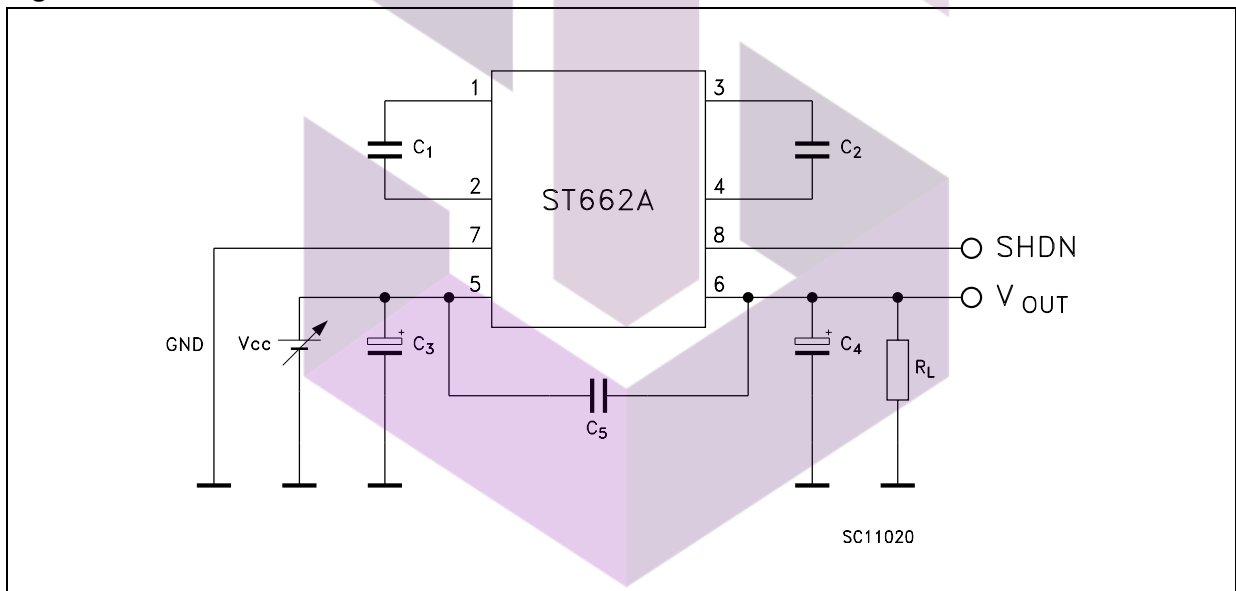

Figure 11. Test circuit



SKYTECH

تهیه و توزیع قطعات الکترونیک

6 Description

The ST662 is an IC developed to provide a 12 V regulated output 30 mA from voltage input as low as 4.75 without any inductors. It is useful for a wide range of applications and its performances make it ideal for Flash memory programming supply.

An evaluation kit is provided to facilitate the application. This include a single-side demo board designed for surface-mount components. The operating principle of ST662 (see [Figure 12](#)) is to charge C1 and C2 capacitor by closing the S1 switch (while S2 is opened) at the V_{CC} voltage. After S1 is opened and S2 closed so that C1 and C2 capacitors are placed in series one to each other, and both are in series with V_{IN} . The sum of V_{C1} and V_{C2} and V_I is applied to the capacitor C4. This works as voltage triple. An amplifier error checks the output voltage and blocks the oscillator if the output voltage is greater than 12 V. The shutdown pin is internally pulled to V_{CC} . When it is held low the output voltage rises to +12 V. [Figure 13](#) shows the transition time of the shut down pin when the V_{SHDN} goes from 5 V to 0 V. Input logic levels of this input are CMOS compatible Applying a logic high at this input, the V_{OUT} oscillator is blocked and the V_{OUT} is reach the V_I value by D1. In this condition I_{CC} is low as 1 μ A. The [Figure 14](#) shows the transition time of the shut down pin when the V_{SHDN} goes from 0 V to 5 V.

Figure 12. Operating principle circuit

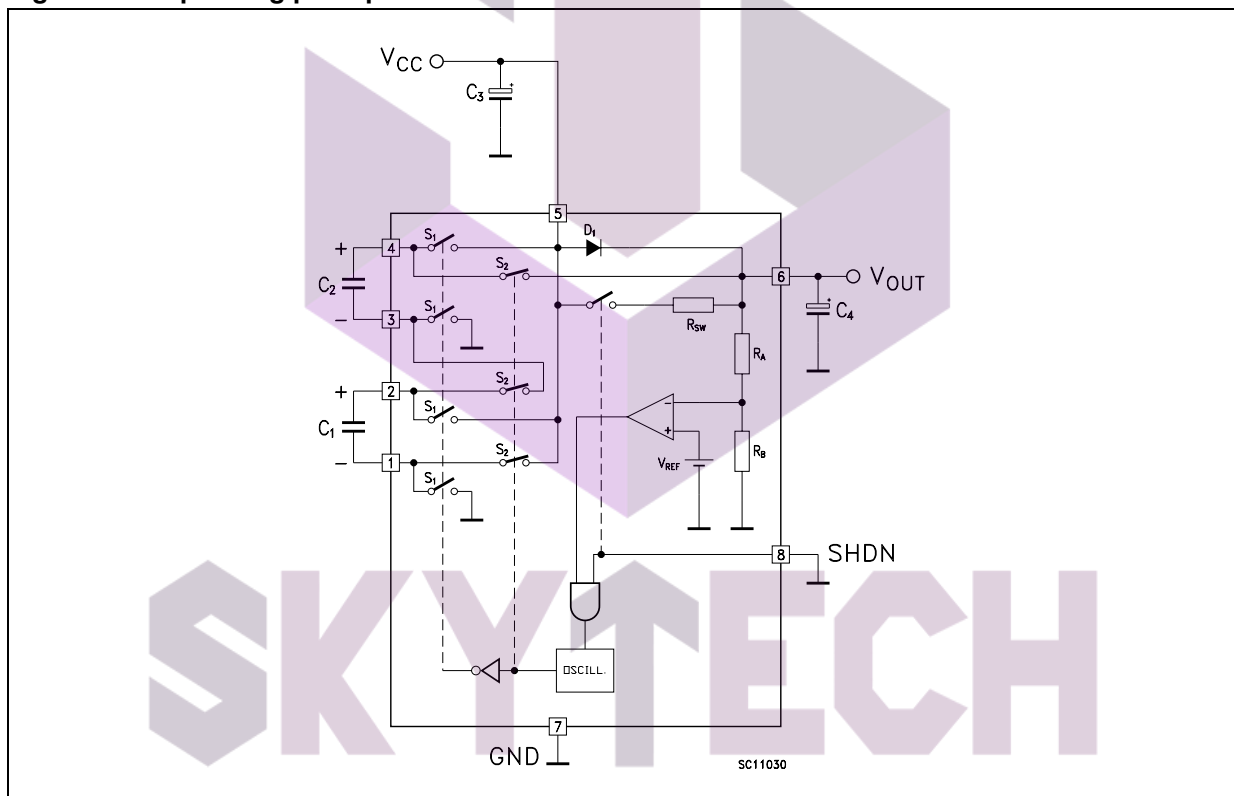

تهیه و توزیع قطعات الکترونیک

Figure 13. Exiting shutdown

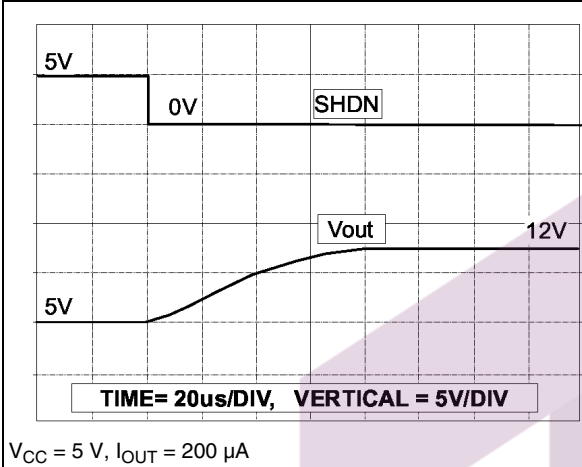
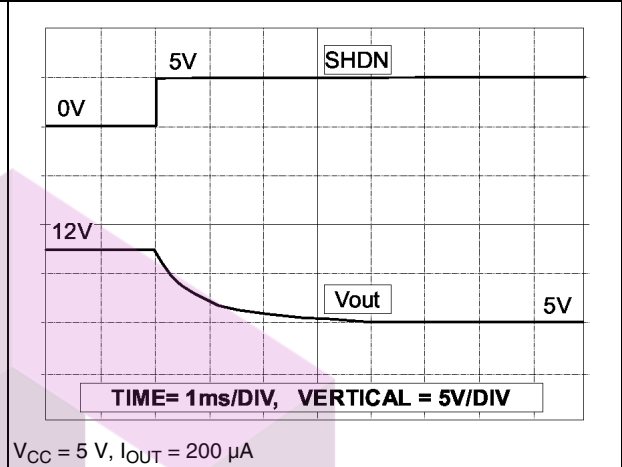

Figure 14. Entering shutdown



SKYTECH

تهیه و توزیع قطعات الکترونیک

7 Application circuit

Based on fast charge/discharge of capacitors, this circuit involves high di/dt values limited only by R_{ON} of switches. This implies a critical layout design due to the need to minimize inductive paths and place capacitors as close as possible to the device.

A good layout design is strongly recommended for noise reason. For best performance, use very short connections to the capacitors and the values shown in [Table 7](#).

C3 and C4 must have low ESR in order to minimize the output ripple. Their values can be reduced to 2 μF and 1 μF , respectively, when using ceramic capacitors, but must be of 10 μF or larger if aluminium electrolytic are chosen.

C5 must be placed as close to the device as possible and could be omitted if very low output noise performance are not required.

[Figure 15](#) and [Figure 16](#) show, respectively, our EVALUATION kit layout and the relatively.

Figure 15. KIT layout

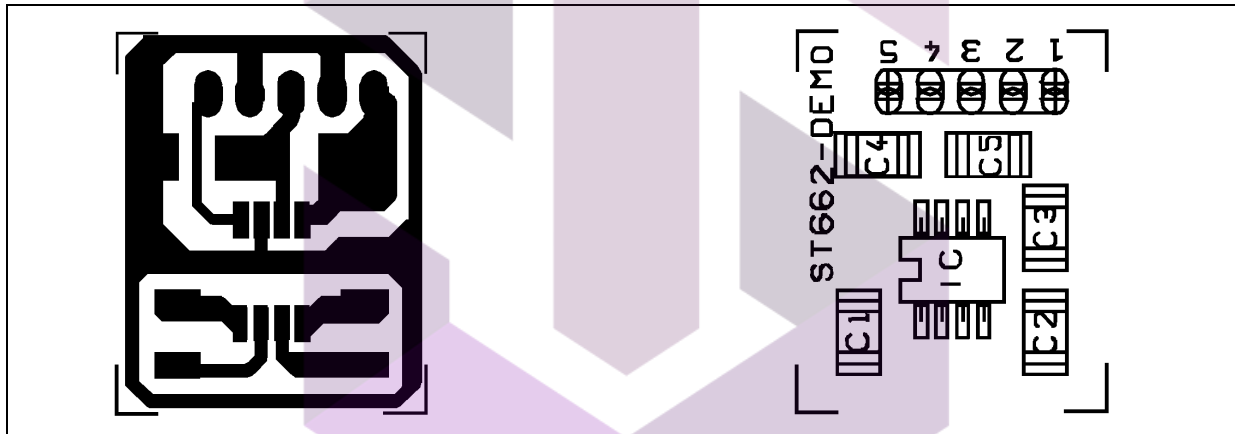

SKYTECH

تهیه و توزیع قطعات الکترونیک

Figure 16. Electrical schematic

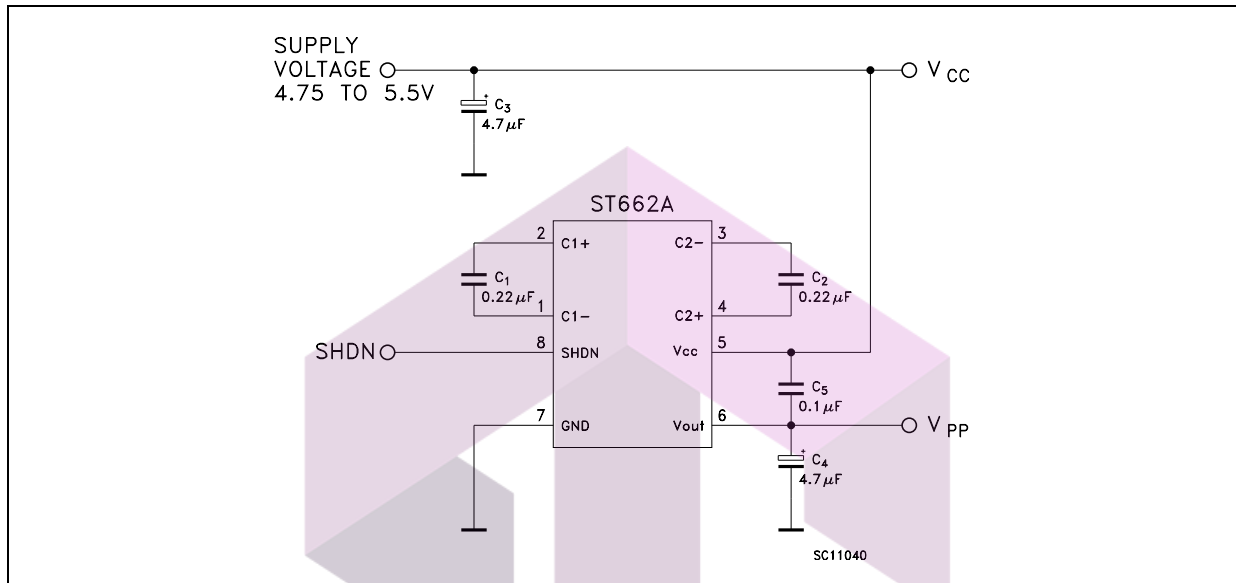

Table 7. List of component

Capacitor	Type	Value (µF)
Charge pump C1	Ceramic	0.22
Charge pump C1	Ceramic	0.22
Input C3	Electrolytic tantalum	4.7
Output C4	Electrolytic tantalum	4.7
Decoupling C5	Ceramic	0.1

7.1 ST662A output performance

Figure 17. Output voltage vs. output current

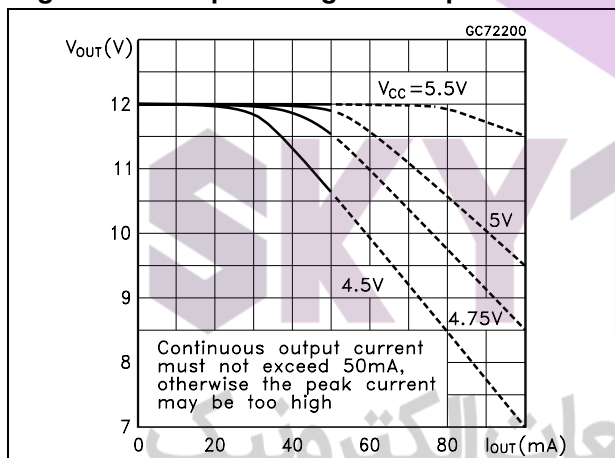

Figure 18. Efficiency vs. output current

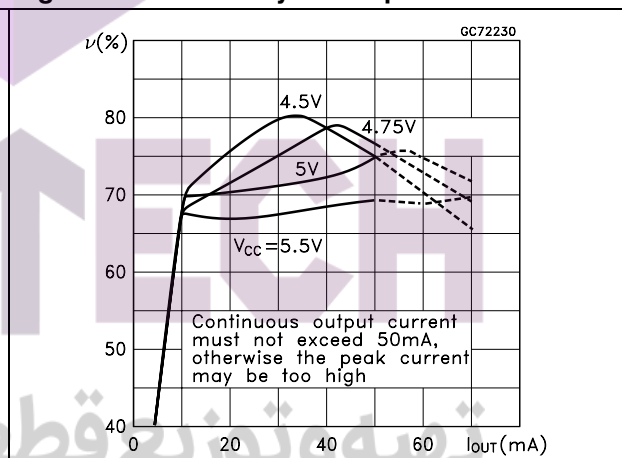

Figure 19. Load transient response
($I_{OUT} = 0$ to 30 mA)

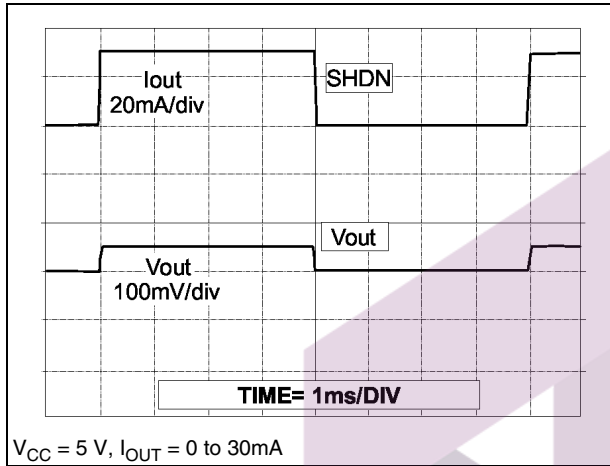
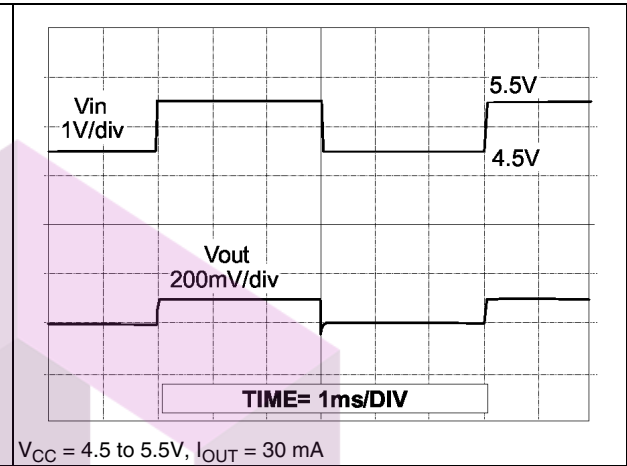

Figure 20. Load transient response
($I_{OUT} = 30\text{ mA}$)



SKYTECH

تهیه و توزیع قطعات الکترونیک

8 How to increase output current or output voltage capability

Current capability is limited by R_{ON} of internal switches. It is possible to increase it connecting in parallel two or more ST662A devices; each one of them can supply 30 mA. The *Figure 19* shows the electric schematic. The capacitors C3, C4 and C5 must be placed very close to the ICs on the board. If this is not possible, you can place two different capacitors, each of them of half value, very close to the respective integrated circuit.

Figure 23 show the output current capability of the proposed circuit.

If an output voltage greater than 12 V is required, it's possible to realize the circuit of the following diagram *Figure 22*. The relevant output current capability is shown in *Figure 24* in which is shown the output voltage vs. load current.

Figure 21. Application circuit for two ST662A in parallel

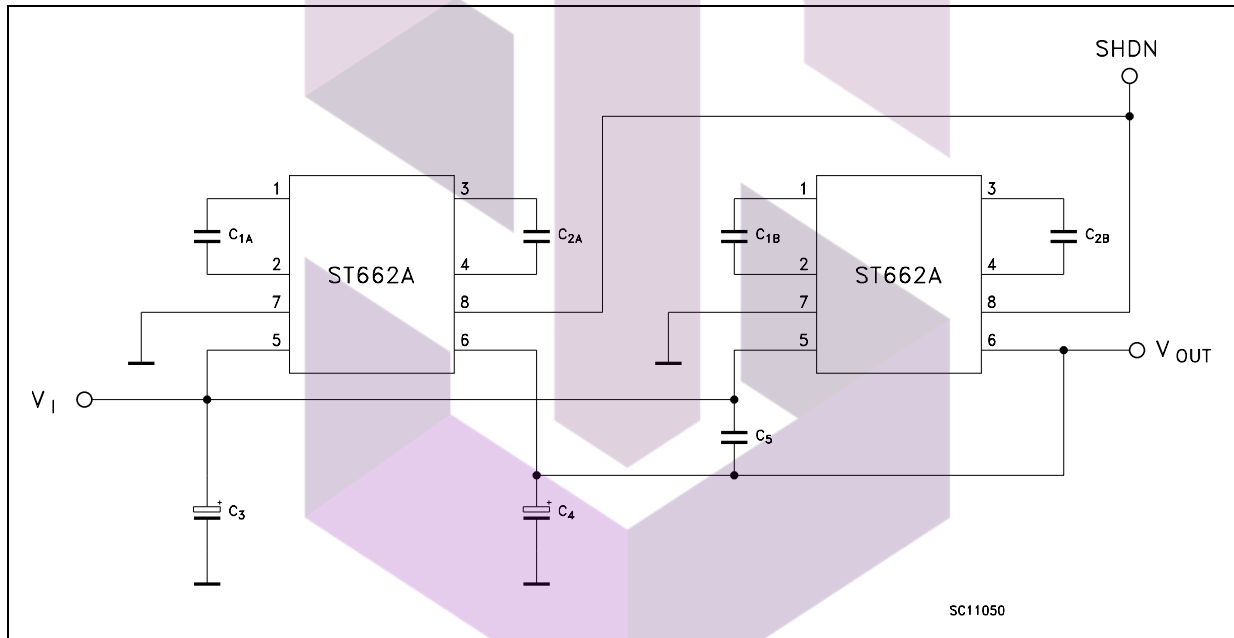

Table 8. List of component

Capacitor	Type	Value (µF)
C1A	Ceramic	0.22
C2A	Ceramic	0.22
C1B	Ceramic	0.22
C2B	Ceramic	0.22
C3	Electrolytic Tantalum	10
C4	Electrolytic Tantalum	10
C5	Ceramic	0.22

Figure 22. Application circuit for output voltage greater than 12 V

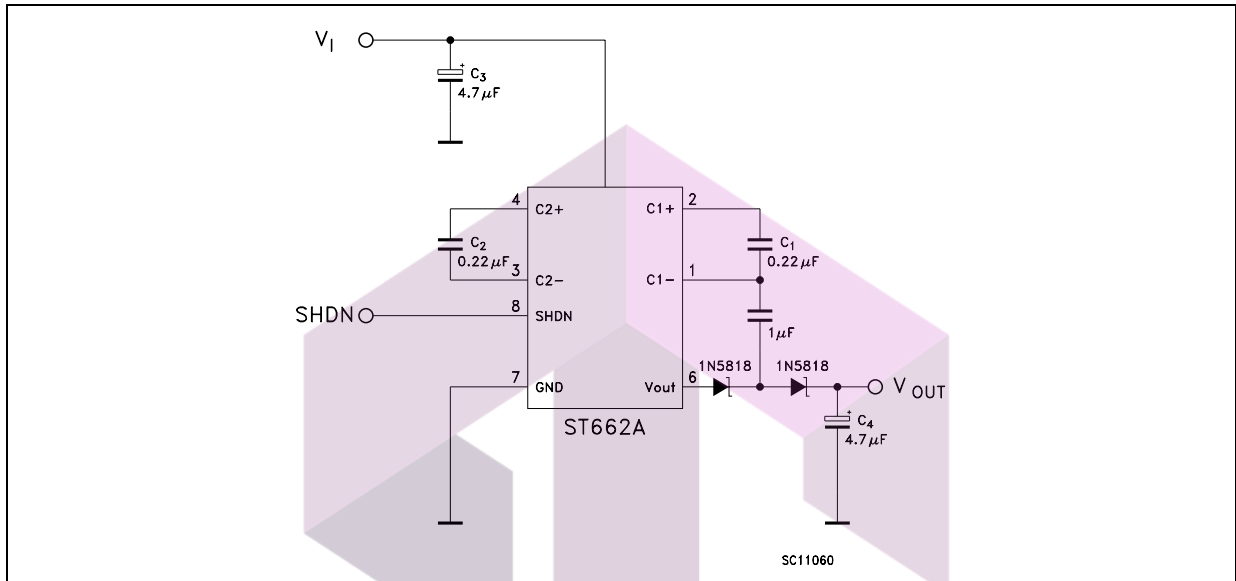

Figure 23. Output voltage for application with two device in parallel

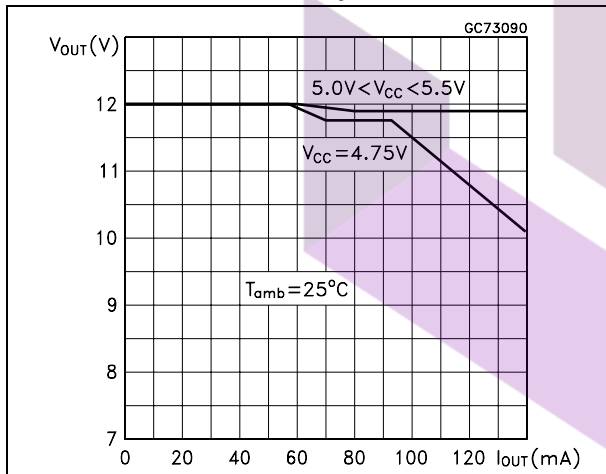
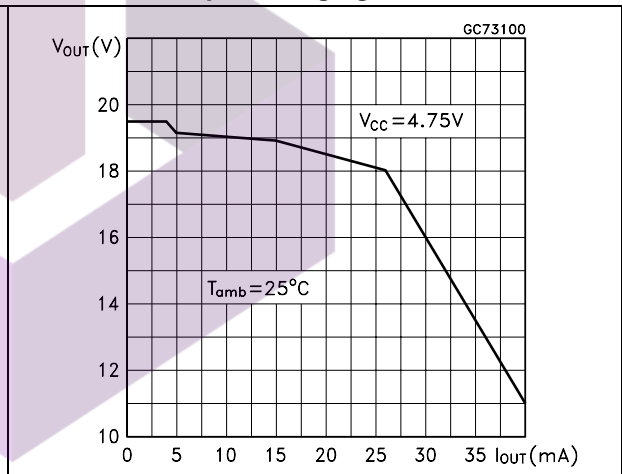

Figure 24. Output voltage for application with output voltage greater than 12 V



SKYTECH

تهیه و توزیع قطعات الکترونیک

9 Package mechanical data

In order to meet environmental requirements, ST offers these devices in different grades of ECOPACK® packages, depending on their level of environmental compliance. ECOPACK® specifications, grade definitions and product status are available at: www.st.com. ECOPACK® is an ST trademark.



SO-8 mechanical data

Dim.	mm.			inch.		
	Min.	Typ.	Max.	Min.	Typ.	Max.
A	1.35		1.75	0.053		0.069
A1	0.10		0.25	0.04		0.010
A2	1.10		1.65	0.043		0.065
B	0.33		0.51	0.013		0.020
C	0.19		0.25	0.007		0.010
D	4.80		5.00	0.189		0.197
E	3.80		4.00	0.150		0.157
e		1.27			0.050	
H	5.80		6.20	0.228		0.244
h	0.25		0.50	0.010		0.020
L	0.40		1.27	0.016		0.050
k	8° (max.)					
ddd			0.1			0.04

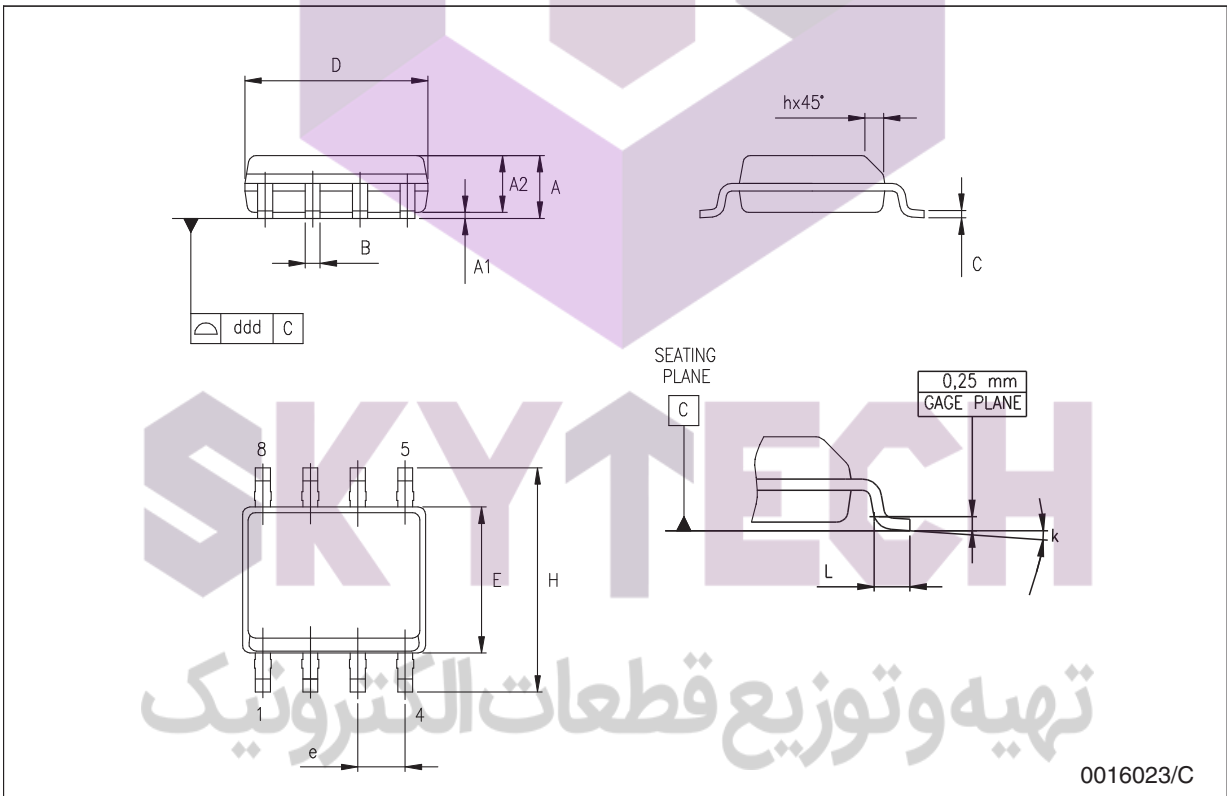

Tape & reel SO-8 mechanical data

Dim.	mm.			inch.		
	Min.	Typ.	Max.	Min.	Typ.	Max.
A			330			12.992
C	12.8		13.2	0.504		0.519
D	20.2			0.795		
N	60			2.362		
T			22.4			0.882
Ao	8.1		8.5	0.319		0.335
Bo	5.5		5.9	0.216		0.232
Ko	2.1		2.3	0.082		0.090
Po	3.9		4.1	0.153		0.161
P	7.9		8.1	0.311		0.319

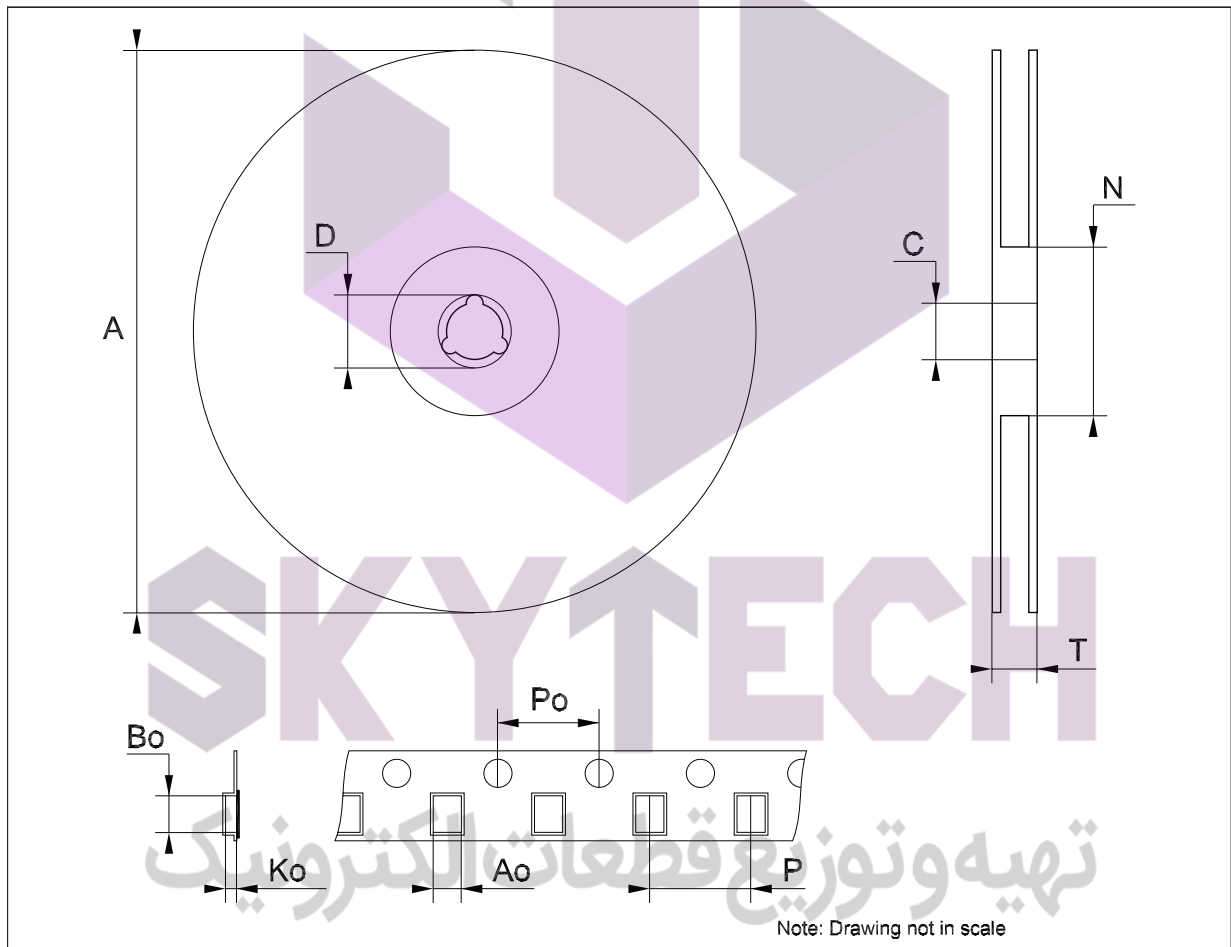

10 Revision history

Table 9. Document revision history

Date	Revision	Changes
16-Jul-2007	5	Device summary updated.
07-Feb-2008	6	Modified: Table 1 on page 1.
19-Feb-2008	7	Add new order code for Automotive grade products see Table 1 on page 1.
03-Aug-2010	8	Modified Features on page 1.



Please Read Carefully:

Information in this document is provided solely in connection with ST products. STMicroelectronics NV and its subsidiaries ("ST") reserve the right to make changes, corrections, modifications or improvements, to this document, and the products and services described herein at any time, without notice.

All ST products are sold pursuant to ST's terms and conditions of sale.

Purchasers are solely responsible for the choice, selection and use of the ST products and services described herein, and ST assumes no liability whatsoever relating to the choice, selection or use of the ST products and services described herein.

No license, express or implied, by estoppel or otherwise, to any intellectual property rights is granted under this document. If any part of this document refers to any third party products or services it shall not be deemed a license grant by ST for the use of such third party products or services, or any intellectual property contained therein or considered as a warranty covering the use in any manner whatsoever of such third party products or services or any intellectual property contained therein.

UNLESS OTHERWISE SET FORTH IN ST'S TERMS AND CONDITIONS OF SALE ST DISCLAIMS ANY EXPRESS OR IMPLIED WARRANTY WITH RESPECT TO THE USE AND/OR SALE OF ST PRODUCTS INCLUDING WITHOUT LIMITATION IMPLIED WARRANTIES OF MERCHANTABILITY, FITNESS FOR A PARTICULAR PURPOSE (AND THEIR EQUIVALENTS UNDER THE LAWS OF ANY JURISDICTION), OR INFRINGEMENT OF ANY PATENT, COPYRIGHT OR OTHER INTELLECTUAL PROPERTY RIGHT.

UNLESS EXPRESSLY APPROVED IN WRITING BY AN AUTHORIZED ST REPRESENTATIVE, ST PRODUCTS ARE NOT RECOMMENDED, AUTHORIZED OR WARRANTED FOR USE IN MILITARY, AIR CRAFT, SPACE, LIFE SAVING, OR LIFE SUSTAINING APPLICATIONS, NOR IN PRODUCTS OR SYSTEMS WHERE FAILURE OR MALFUNCTION MAY RESULT IN PERSONAL INJURY, DEATH, OR SEVERE PROPERTY OR ENVIRONMENTAL DAMAGE. ST PRODUCTS WHICH ARE NOT SPECIFIED AS "AUTOMOTIVE GRADE" MAY ONLY BE USED IN AUTOMOTIVE APPLICATIONS AT USER'S OWN RISK.

Resale of ST products with provisions different from the statements and/or technical features set forth in this document shall immediately void any warranty granted by ST for the ST product or service described herein and shall not create or extend in any manner whatsoever, any liability of ST.

ST and the ST logo are trademarks or registered trademarks of ST in various countries.

Information in this document supersedes and replaces all information previously supplied.

The ST logo is a registered trademark of STMicroelectronics. All other names are the property of their respective owners.

© 2010 STMicroelectronics - All rights reserved

STMicroelectronics group of companies

Australia - Belgium - Brazil - Canada - China - Czech Republic - Finland - France - Germany - Hong Kong - India - Israel - Italy - Japan - Malaysia - Malta - Morocco - Philippines - Singapore - Spain - Sweden - Switzerland - United Kingdom - United States of America

www.st.com